

2MP Vandal-resistant Network IR Fixed Dome Camera

IPC322E-IR-F36 (60)-IN



Key Features

Optics

- Day/night 기능
- SmartIR, 방사거리 30 m (98 ft)
- 3D DNR (디지털 노이즈 감소)

Compression

- 트리플 스트리밍
- ROI (광학 역광 보정)
- 사용자 OSD 편집 지원

Network

- ONVIF

Structure

- 사용 환경 : -35°C to 60°C (-31°F to 140°F)
- 허용전압 : ±25%
- IK10
- IP66

Specifications

	IPC322E-IR-F36-IN	IPC322E-IR-F60-IN
Camera		
센서	1/2.8", 2 megapixel, progressive scan CMOS	
전자 셔터	Auto/Manual, 1/6~1/8000 s	
렌즈	3.6mm	6 mm
화각(H)	84.7°	53.2°
Day/Night	IR-cut filter with auto switch (ICR)	
최저조도	Colour: 0.06 Lux (F1.6, 50IRE) Black & White: 0.03Lux (F1.6, 50IRE)	
S/N	>52dB	
이미지 회전	지원	
Video		
최대 해상도	1920 × 1080	
비디오 압축	H.264,MJPEG	
프리임 레이트	1080P (1920*1080): Max. 30 fps; 720P (1280*720): Max. 30 fps; D1 (720*576): Max. 25 fps	
비디오 스트리밍	트리플	
사용자 OSD 편집지역	Up to 8 OSDs	
사생활 보호 영역설정	Up to 4 areas	
Audio		
오디오 압축	G.711	
양방향 오디오	지원	
Network		
프로토콜	L2TP,IPv4,IGMP,ICMP,ARP,TCP,UDP,DHCP,PPPoE,RTP,RTSP,Qos,NTP,FTP,HTTP,SNMP,SIP	
호환 프로토콜	ONVIF, API	
Interface		
Audio I/O	Input: impedance 35 kΩ; amplitude 2 V [p-p]	
	Output: impedance 600 Ω; amplitude 2 V [p-p]	
Alarm I/O	1/ 1	
네트워크	10M/100M Base-TX Ethernet	
General		
전원	12 V DC, or PoE (IEEE802.3 af)	
	Power consumption: 3.5W(5.5W with IR on)	
치수 (Ø x H)	Ø109 x 81 mm (Ø4.3" x 3.2")	
무게	0.45 kg (0.99 lb)	
사용 환경	-35°C ~ +60°C (-31°F ~ 140°F), Humidity ≤ 90% RH(non-condensing)	
충격 보호 등급	IK10	
IP 등급	IP66	
서지 보호 회로	4KV	

Dimensions

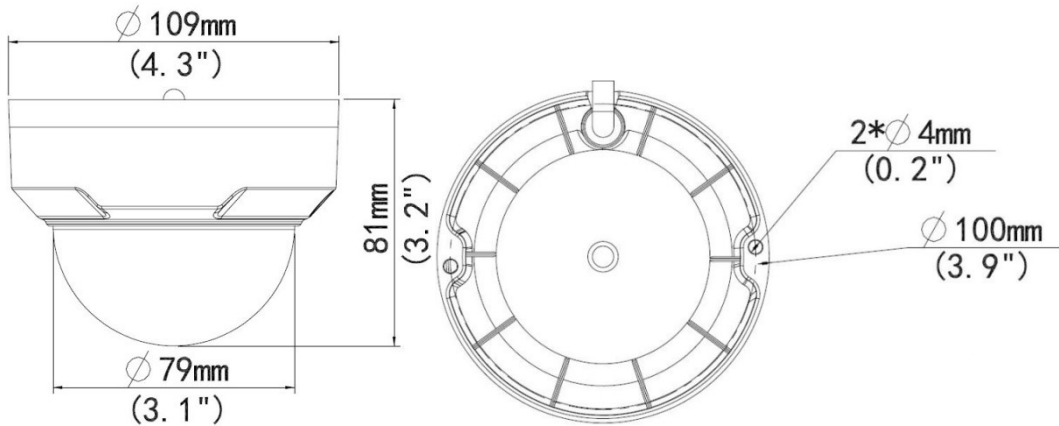

Installation

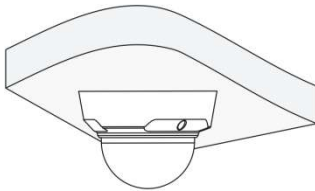

Ceiling mount

Accessories

Installation mode	Accessories	Description
Ceiling mount	Mounting pedestal is included in the Product package	\

Zhejiang Uniview Technologies Co., Ltd.

South Tower, Building 10, Wanlun Science Park, 88 Jiangling Road, Hangzhou, P.R.China 310051

Email: overseasbusiness@uniview.com; globalsupport@uniview.com

<http://www.uniview.com>

©2015 Zhejiang Uniview Technologies Co., Ltd. All rights reserved.

*Product specifications and availability are subject to change without notice.