

2MP Network IR Fixed Dome Camera

IPC3232ER-DV(VS)



Key Features

Optics

- Day/night 기능
- Smart IR, 방사거리 30 m (98 ft)
- 저조도 감시
- 3D DNR (디지털 노이즈 감소)

Compression

- H.264
- 트리플 스트리밍
- ROI (관심 지역 촬영)
- 9:16 복도 모드

Network

- ONVIF

Structure

- POE 지원
- 사용환경 : -40°C to 60°C (-40°F to 140°F)
- 허용전압 : ±25%
- IK10
- IP66

Specifications

	IPC3232ER-DV	IPC3232ER-VS
Camera		
센서	1/2.8", 2 megapixel, progressive scan CMOS	1/2.9", 2 Megapixel, progressive scan CMOS
전자 셔터	Auto/Manual, 1/6~1/8000 s	
렌즈	2.8~12 mm@F1.4; Angle of View (H): 100.0° (wide) ~30° (tele)	
Zoom/Focus	Manual	
최저조도	Colour: 0.03 Lux (F1.4, 50IRE) Black & White: 0.01Lux (F1.4, 50IRE)	
Day/Night	IR-cut filter with auto switch (ICR)	
IR Range	최대 30m (98 ft) IR range	
S/N	>52dB	
WDR	Optical WDR(up to 120dB)	Digital WDR
Video		
최대 해상도	1920 × 1080	
비디오 압축	H.264,MJPEG	
프레임 레이트	1080P (1920×1080): Max. 30 fps; 720P (1280×720): Max. 30 fps; D1 (720×576): Max. 25 fps	
9:16 복도 모드	지원	
ROI	지원	
비디오 스트리밍	트리플	
사용자 OSD 편집지역	Up to 8 OSDs	
사생활 보호 영역설정	Up to 4 areas	
Audio		
오디오 압축	G.711	N/A
양방향 오디오	지원	N/A
Storage		
Edge Storage	Micro SD, up to 128 GB	
Network		
프로토콜	L2TP,IPv4,IGMP,ICMP,ARP,TCP,UDP,DHCP,PPPoE,RTP,RTSP,Qos,NTP,FTP,HTTP,SNMP,SIP	
호환 프로토콜	ONVIF, API	
Interface		
오디오 I/O	audio cable	N/A
	Input: impedance 35 kΩ; amplitude 2 V [p-p]	N/A
	Output: impedance 600 Ω; amplitude 2 V [p-p]	N/A
알람 I/O	1/ 1	N/A
네트워크	1 RJ45 10M/100M Base-TX Ethernet	
비디오 출력	1 BNC, impedance 75 Ω; amplitude 1 V [p-p]	N/A
리셋	1 Reset Button	
POE 전원	DC12V Power Output With PoE	
General		
전원	12 V DC, or PoE (IEEE802.3 af)	
	Power consumption: max.6.6 W (PoE :max.7.2 W)	
치수 (Ø x H)	Φ148 x 111.3 mm (Ø5.8" x 4.4")	

무게	0.75 kg (1.7 lb)
사용 환경	-40°C ~ +60°C (-40°F ~ 140°F), Humidity ≤ 90% RH(non-condensing)
충격 보호 등급	IK10
IP 등급	IP66
서지 보호 회로	4KV

Dimensions

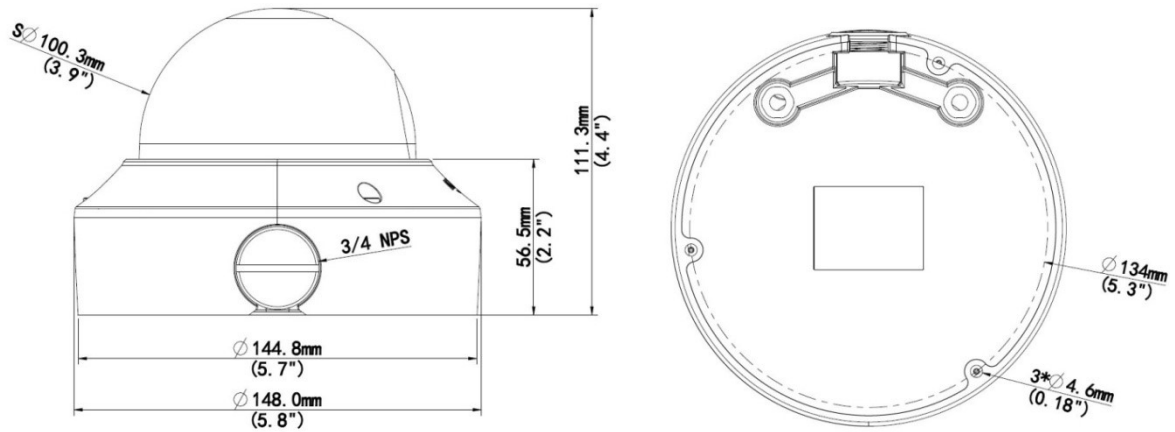

Accessories

Installation mode	Accessories	Description
Ceiling mount	Mounting pedestal is included in the product package	For indoor ceiling installation

Zhejiang Uniview Technologies Co., Ltd.

Building No.10, Wanlun Science Park, Jiangling Road 88, Binjiang District, Hangzhou, Zhejiang, China (310051)

Email: overseasbusiness@uniview.com; globalsupport@uniview.com

<http://www.uniview.com>

©2015 Zhejiang Uniview Technologies Co., Ltd. All rights reserved.

*Product specifications and availability are subject to change without notice.