

2MP WDR (Motorized) VF Vandal-resistant Network IR Fixed Dome Camera

IPC3232ER3-DVZ28



Key Features

Optics

- Day/night functionality
- Smart IR, up to 30m (98 ft) IR distance
- Up to 120 dB Optical WDR(Wide Dynamic Range)
- Lowlight surveillance
- 3D DNR (Digital Noise Reduction)
- Built-in motorized lens for remote zoom

Compression

- H.265
- Triple streams
- ROI (Region of Interest)
- 9:16 corridor mode

Network

- ONVIF Conformance

Structure

- Support PoE power supply
- Built-in PoE splitter that outputs DC 12V

- Wide temperature range: -40°C to 60°C (-40°F to 140°F)
- Wide voltage range of ±25%
- IK10 vandal resistant
- IP66

Specifications

| IPC3232ER3-DVZ28 | |
|------------------------|--|
| Camera | |
| Sensor | 1/3", 2.0 megapixel, progressive scan CMOS |
| Shutter | Auto/Manual, 1/6~1/8000 s |
| Lens | 2.8~12 mm@F1.6; Angle of View (H): 90° (wide) ~28° (tele) |
| Zoom/Focus | Motor drive |
| Min. Illumination | Colour: 0.02 Lux (F1.6, AGC ON) 0 Lux with IR |
| Day/Night | IR-cut filter with auto switch (ICR) |
| IR Range | Up to 30m (98 ft) IR range |
| S/N | >52dB |
| WDR | Optical WDR (up to 120 dB) |
| Video | |
| Max. Resolution | 1920 x 1080 |
| Video Compression | H.265,H.264,MJPEG |
| Capture Collect Mode | 1080P (1920 x 1080) @30 fps; 1080P (1920 x 1080) @25fps |
| 9:16 Corridor Mode | Supported |
| ROI | Supported |
| Video Streaming | Triple |
| OSD | Up to 8 OSDs |
| Privacy Mask | Supported |
| Audio | |
| Audio Compression | G.711 |
| Two-way audio | Supported |
| Storage | |
| Edge Storage | Micro SD, up to 128 GB |
| Network | |
| Protocols | L2TP, IPv4, IGMP, ICMP, ARP, TCP, UDP, DHCP, PPPoE, RTP, RTSP, DNS, DDNS, NTP, FTP, UPnP, HTTP, HTTPS, FTP, SMTP, SNMP, SIP, QoS |
| Compatible Integration | ONVIF, API |
| Interface | |
| Audio I/O | Audio cable |
| | Input: impedance 35 kΩ; amplitude 2 V [p-p] |
| | Output: impedance 600 Ω; amplitude 2 V [p-p] |
| Alarm I/O | 1/ 1 |
| Network | 1 RJ45 10M/100M Base-TX Ethernet |

| | |
|---------------------|--|
| Video Output | 1 BNC, impedance 75 Ω; amplitude 1 V [p-p] |
| Reset | 1 Reset Button |
| Power Output | DC12V Power Output With PoE |
| General | |
| Power | 12 V DC, or PoE (IEEE802.3 af) |
| | Power consumption: Max.6.6 W (PoE :Max.7.2 W) |
| Dimensions (Ø x H) | Φ148 x 111.3 mm (Ø5.8" x 4.4") |
| Weight | 0.75 kg (1.7 lb) |
| Working Environment | -40°C ~ +60°C (-40°F ~ 140°F), Humidity ≤ 95% RH(non-condensing) |
| Vandal Resistant | IK10 |
| Ingress Protection | IP66 |

Dimensions

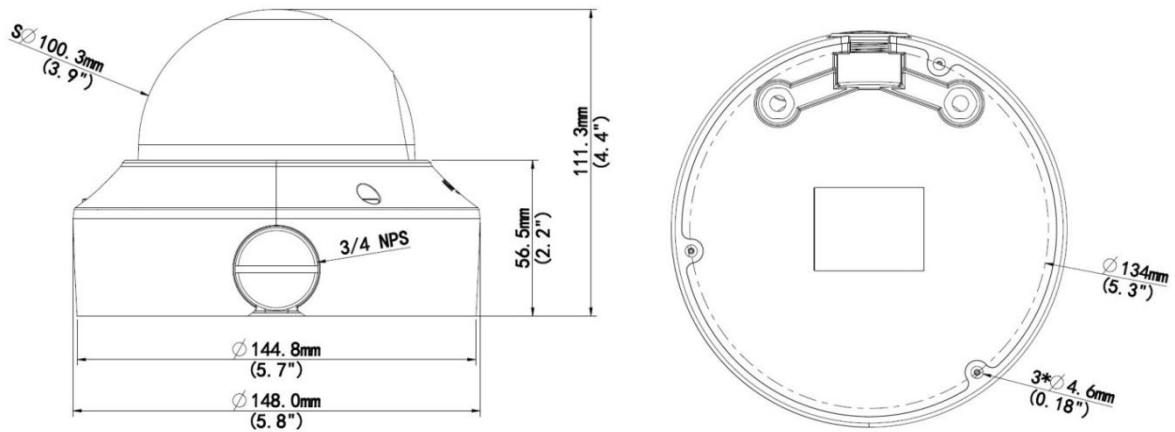

Accessories

| Installation mode | Accessories | Description |
|-------------------|--|---------------------------------|
| Ceiling mount | Mounting pedestal is included in the product package | For indoor ceiling installation |

Zhejiang Uniview Technologies Co., Ltd.

Building No.10, Wanlun Science Park, Jiangling Road 88, Binjiang District, Hangzhou, Zhejiang, China (310051)

Email: overseasbusiness@uniview.com; globalsupport@uniview.com

<http://www.uniview.com>

©2016 Zhejiang Uniview Technologies Co., Ltd. All rights reserved.

*Product specifications and availability are subject to change without notice.